

Queue cône Morse

Morse taper shank

Mango

Cono Morse

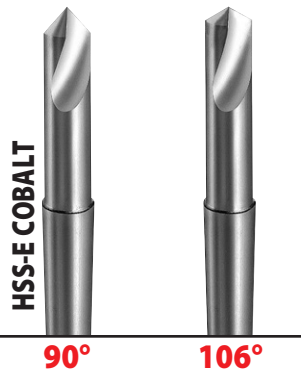

90°

106°

D	L	ℓ1	ℓ2	MORSE	magafor	magafor
h10	± 1	+1	+1	N°	198	1906
10,0	130	25	64	1	102,76 €	
12,0	130	30	64	1	107,62 €	119,79 €
16,0	148	35	68	2	132,55 €	148,37 €
20,0	148	40	68	2	158,10 €	176,33 €
25,0	171	45	72	3	217,69 €	240,79 €

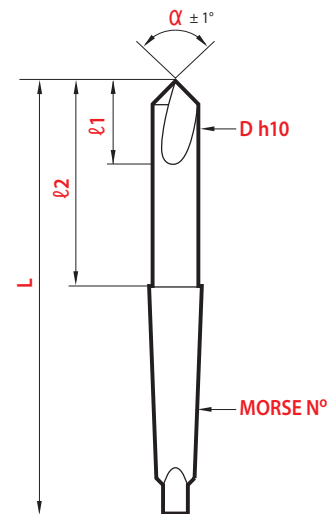

COMBI-mag

Outils multi-fonctions

multi-function tools

Herramientas multi-función

Utensili multi-funzione

90°

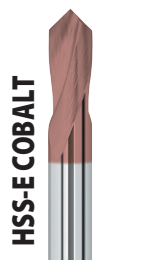

COMBI-mag

D h7	L	ℓ	T*	Red'X	
inch	mm	± 1	+1	007	
	3	50	6	0,3	18,85 €
1/8"	3,17	50	6	0,3	18,85 €
	4	52	8	0,4	19,46 €
3/16"	4,76	60	9	0,5	20,06 €
	5	60	10	0,5	20,06 €
	6	66	12	0,6	23,71 €
1/4"	6,35	66	12	0,6	24,93 €
5/16"	7,93	79	14	0,8	27,67 €
	8	79	14	0,8	27,67 €
3/8"	9,52	89	16	1	31,62 €
	10	89	16	1	32,83 €
	12	102	18	1,2	42,56 €
1/2"	12,7	102	19	1,3	44,99 €
	14	115	21	1,4	60,21 €
5/8"	15,87	115	24	1,6	62,64 €
	16	115	24	1,6	62,64 €

*T = 0,1 D Épaisseur d'âme Web thickness Espesor del núcleo Spessore in punta del nocciolo

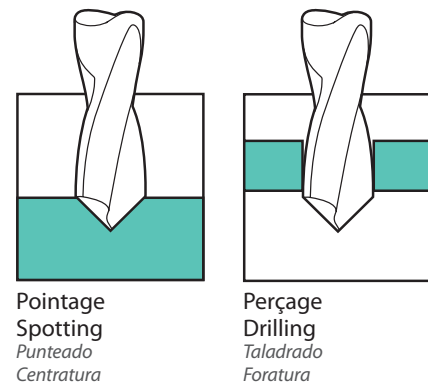

Pointage
Spotting
Punteado
Centratura

Perçage
Drilling
Taladrado
Foratura

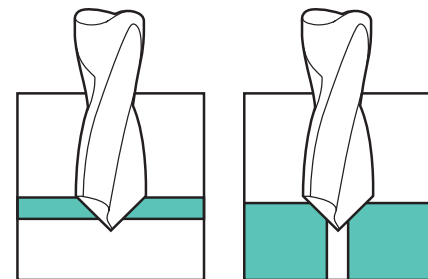

Chanfrein direct
Direct chamfer
Chafilanes directos
Svasatura rapida

Chanfreinage
Chamfering
Chafilado
Sbavatura

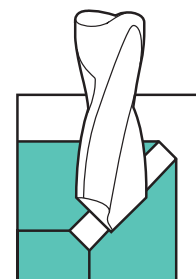

Chanfrein longitudinal
Longitudinal chamfer
Chafilanes longitudinales
Smussi longitudinali

Promo-kits



6 COMBI-mag Ø 4 - 5 - 6 - 8 - 10 - 12
007 166,61 €