



Les bouts d'arbres filetés

For threaded holes

Para los extremos de ejes roscados

Per le estremità di alberi filettati



Principale utilisation :
pour centrer et percer les axes de moteurs électriques, pompes et moto-réducteurs.

Ces forets à centrer sont conçus pour réaliser en une seule opération :

- 1 - l'avant-trou de taraudage,
- 2 - l'entrée de taraud,
- 3 - le centre.

Les codes **0280 - 0288 - 0284** ont un plat de serrage et pour le logement d'un outil de dressage. Les deux rainures latérales facilitent la lubrification.

Main use :

to center and to bore the shafts of electric motors, pumps and speed-reducing gear.

These Center drills are designed to do the following in a single operation :

- 1 - make the preliminary tap hole,
- 2 - make the tap entrance,
- 3 - do the centering.

The code **0280 - 0288 - 0284** have a flat for a blocking screw and carbide insert. The two side grooves facilitate lubrication.

Usa principal :

Centrado y taladrado de ejes de motores eléctricos, bombas, motoreductores.

Estas brocas de centrar están

diseñadas para realizar en una sola operación :

- 1 - el agujero previo de roscado,
- 2 - la entrada de rosca,
- 3 - el centrado.

El código 0280 - 0288 - 0284 incorporan un plano de bloqueo para el tornillo de apriete y la placa de metal duro. Las dos ranuras laterales facilitan la lubricación.

Principale impiego :

per centrare e forare gli assi di motori elettrici, pompe e moto-riduttori.

Queste punte a centrare sono concepite per realizzare in un'unica operazione :

- 1 - l'avanforo di filettatura,
- 2 - l'imboccatura per il maschio,
- 3 - la centratura.

Gli articoli 0280 - 0288 - 0284 presentano un piano di bloccaggio anche per il posizionamento all'interno di una macchina intestatrice. Le due scanalature laterali favoriscono la lubrificazione.

Forme D

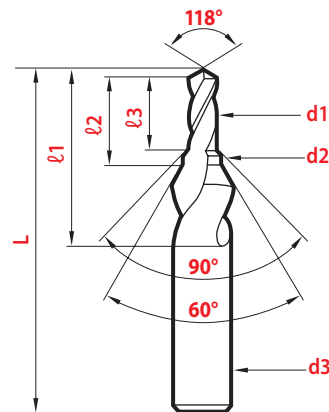
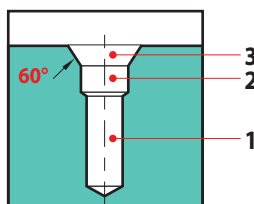

Forme DR

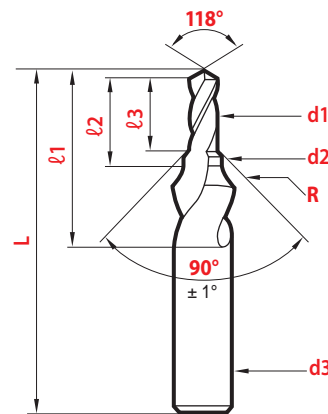
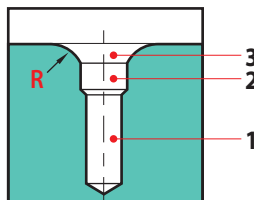

Forme DS

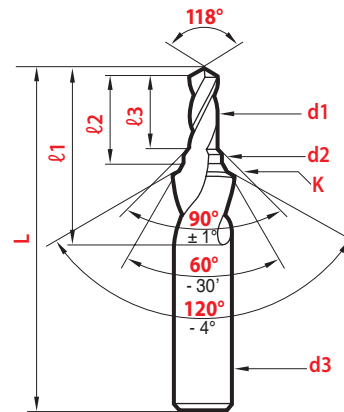
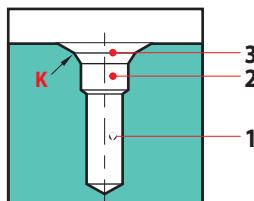

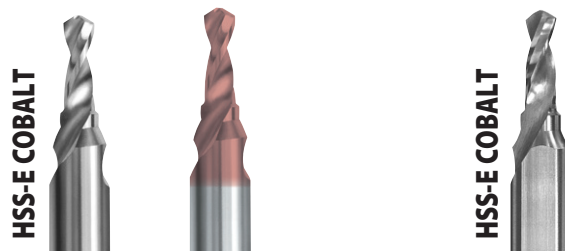

DIN 332/2 - **Forme D**

Sans plat
Without flat
Sin plano
Senza piano



Avec plat
With flat
Con plano
Con piano

VIS VITE Kernloch	d1 -0/-0,05	d2 ± 0,5	d3 h7	L ± 1	ℓ1	ℓ2	ℓ3	magafor 0285	Red'X 0985	P -0,1	magafor 0280
M3	2,5	3,2	6,0	55	18	9,0	8	54,73 €	61,70 €		
M4	3,3	4,3	8,0	63	23	12,6	11	48,64 €	59,12 €	6,75	66,89 €
M5	4,2	5,3	10,0	67	27	15,1	13	57,77 €	70,57 €	8,45	72,97 €
M6	5,0	6,4	12,5	71	33	18,9	16	66,89 €	83,10 €	10,45	91,21 €
M8	6,8	8,4	14,0	88	41	23,0	19	72,97 €	91,06 €	12,50	97,29 €
M10	8,5	10,5	16,0	90	47	27,7	23	85,13 €	109,77 €	14,85	109,45 €
M12	10,2	13,0	20,0	105	59	34,5	28	103,37 €	139,04 €	18,45	133,78 €
M16	14,0	17,0	25,0	132	67	41,3	33			23,45	255,39 €
M20	17,5	21,0	31,5	145	77	48,3	38			29,35	352,68 €
M24	21,0	25,0	40,0	160	90	57,0	45			36,50	547,27 €

DIN 332/2 - **FORME DR**

Sans plat
Without flat
Sin plano
Senza piano



Avec plat
With flat
Con plano
Con piano

VIS VITE Kernloch	d1 -0/-0,05	d2 ± 0,5	d3 h7	L ± 1	ℓ1	ℓ2	ℓ3	R*	magafor 0287	P -0,1	magafor 0288
M4	3,3	4,3	8,0	63	23	12,6	11	4	57,77 €	6,75	79,04 €
M5	4,2	5,3	10,0	67	27	15,1	13	6	66,89 €	8,45	85,13 €
M6	5,0	6,4	12,5	71	33	18,9	16	8	79,04 €	10,45	103,37 €
M8	6,8	8,4	14,0	88	41	23,0	19	10	88,17 €	12,50	112,50 €
M10	8,5	10,5	16,0	90	47	27,7	23	16	100,33 €	14,85	124,66 €
M12	10,2	13,0	20,0	105	59	34,5	28	20	121,62 €	18,45	155,06 €
M16	14,0	17,0	25,0	132	70	41,3	33	25		23,40	291,87 €
M20	17,5	21,0	31,5	145	77	48,3	38	31,5		29,35	425,65 €
M24	21,0	25,0	40,0	160	98	57	45	40		36,50	626,31 €

*R maxi = 1,25 R

DIN 332/2 - **FORME DS**

Sans plat
Without flat
Sin plano
Senza piano



Avec plat
With flat
Con plano
Con piano

VIS VITE Kernloch	d1 -0/-0,05	d2 ± 0,5	d3 h7	L ± 1	ℓ1	ℓ2	ℓ3	K js13	magafor 0283	P -0,1	magafor 0284
M4	3,3	4,3	8	63	23	12,6	11	6,4	57,77 €	6,75	79,04 €
M5	4,2	5,3	10	67	27	15,1	13	7,8	66,89 €	8,45	85,13 €
M6	5,0	6,4	12,5	71	33	18,9	16	9,1	79,04 €	10,45	103,37 €
M8	6,8	8,4	14,0	88	41	23,0	19	11,8	88,17 €	12,50	112,50 €
M10	8,5	10,5	18,0	90	47	27,7	23	14,2	100,33 €	14,85	124,66 €
M12	10,2	13,0	20,0	105	59	34,5	28	17,4	121,62 €	18,45	155,06 €
M16	14,0	17,0	26,0	132	70	41,3	33	21,9		23,40	291,87 €

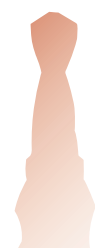

Revêtements : nous consulter.

Coating : please inquire

Recubrimiento : sobre pedido

Rivestimento : consultateci