

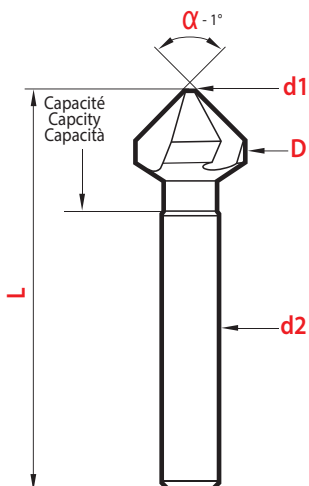

# Fraises à noyer trois dents • Three flute countersinks

Avellanadores de tres labios • Frese coniche con tre denti

## 82° - 100° - 120°

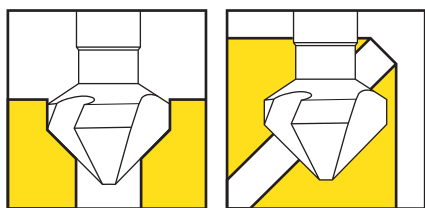

### 82°

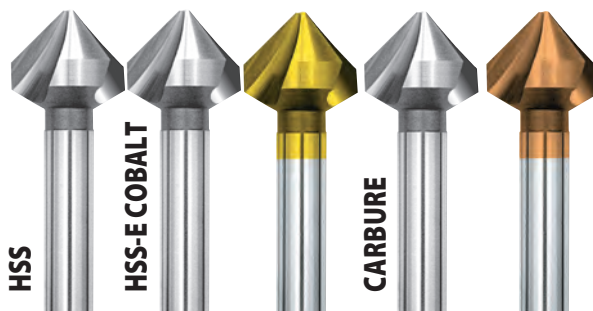

D z9	d1	d2	L	HSS 4304	magafor 434	TiN 4834	magaforce 8434	Hard'X 8434-H
mm (inch)	maxi	h9	± 1					
6,3	1,5	5	45	22,15 €	31,20 €	35,25 €		
6,35 (1/4")	1,5	6,35	45		31,20 €	35,05 €		
7,93 (5/16")	2,0	6,35	45		32,90 €	38,15 €		
8,3	2,0	6	50	23,40 €	32,90 €	38,15 €		
9,52 (3/8")	2,5	6,35	50		34,65 €	39,90 €		
10,4	2,5	6	50	24,65 €	34,65 €	39,90 €	161,15 €	178,20 €
12,4	2,8	8	56	32,40 €	45,65 €	51,70 €	176,35 €*	195,80 €*
12,7 (1/2")	2,9	6,35	50		45,65 €	51,70 €		
15,87 (5/8")	3,2	9,52	60		52,00 €	57,80 €		
16,5	3,2	10	61	36,90 €	52,00 €	57,80 €	201,90 €*	221,35 €*
19,05 (3/4")	3,5	9,52	60		59,50 €	67,05 €		
20,5	3,5	10	64	42,30 €	59,50 €	67,05 €	285,80 €*	307,70 €*
25,0	3,8	10	68	54,00 €	76,25 €	85,50 €	377,05 €*	405,00 €*
25,4 (1")	3,8	9,52	70		76,25 €	85,50 €		
31,0	4,2	12	73		112,05 €	123,65 €		

\* Queue avec 3 plats pour un serrage optimum de l'outil.  
Shanks with 3 flats to optimize tool holding.  
3 planos en el mango para optimizar la sujeción de la herramienta.  
Codolo con 3 piani per un bloccaggio ottimale dell'utensil

Les fraises **magaforce** sont en CARBURE MONOBLOC. Cette conception leur confère une solidité unique

Three flute countersinks the **magaforce** cutters are made from solid carbide. this design offers a unique strength.

AVELLANADORES De tres labios Las herramientas **magaforce** están fabricadas en METAL DURO INTEGRAL. Este concepto ofrece una rigidez única.

FRESE CONICHE con tre denti Le frese **magaforce** sono in METALLO DURO INTEGRALE. Questa struttura conferisce loro una solidità unica.

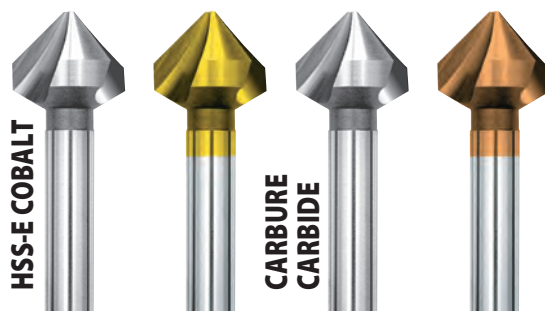

### 100°

D z9	d1	d2	L	magafor 435	TiN 4835	magaforce 8435	Hard'X 8435-H
	maxi	h9	± 1				
6,3	1,5	5	44	38,10 €	41,90 €	127,70 €	138,65 €
8,3	2,0	6	49	39,85 €	45,05 €	145,95 €	159,35 €
10,4	2,5	6	49	41,60 €	47,40 €	161,15 €	178,20 €
12,4	2,8	8	55	52,55 €	57,80 €	176,35 €*	195,80 €*
16,5	3,2	10	59	61,80 €	67,60 €	201,90 €*	221,35 €*
20,5	3,5	10	62	72,80 €	79,75 €	285,80 €*	307,70 €*
25,0	3,8	10	65	87,80 €	96,80 €		
31,0	4,2	12	68	128,25 €	139,80 €		

\* Queue avec 3 plats pour un serrage optimum de l'outil.  
Shanks with 3 flats to optimize tool holding.  
3 planos en el mango para optimizar la sujeción de la herramienta.  
Codolo con 3 piani per un bloccaggio ottimale dell'utensil

## Performances

> p. 48

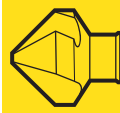

**120°**

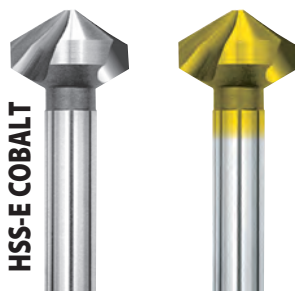

D	d1	d2	L	magafor 433	TiN 4833
z9	maxi	h9	± 1		
6,3	1,5	5	43	31,20 €	35,25 €
8,3	2,0	6	48	32,90 €	38,15 €
10,4	2,5	6	48	34,65 €	39,90 €
12,4	2,8	8	54	45,65 €	51,70 €
16,5	3,2	10	57	52,00 €	57,80 €
20,5	3,5	10	59	59,50 €	67,05 €
25,0	3,8	10	62	76,25 €	85,50 €
31,0	4,2	12	65	112,05 €	123,65 €

**Cônes morse**  
**Morse taper**  
*Cono morse*

**120°**

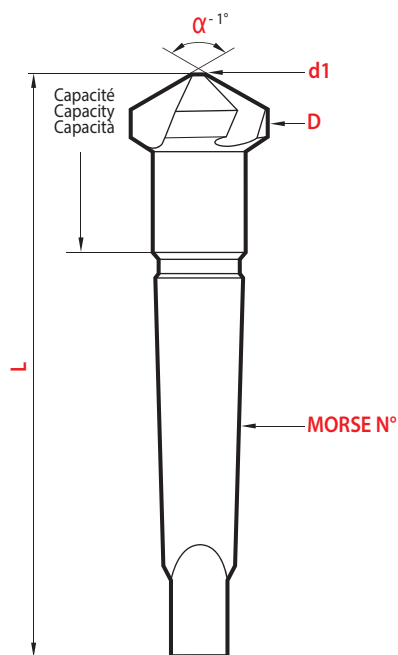

magafor standard

D	d1	MORSE N°	L	magafor 433
z9	maxi	N°	± 1	
20,5	4	1	91	125,90 €
31,0	5	2	106	165,20 €
40,0	8	3	154	253,00 €

*promo-kits*



Composition Composición Composizione	α	Qualité Quality calidad	magafor	
5 fraises 5 cutters 5 fresas 5 frese Ø 10,4 - 16,5 20,5 - 25,0 - 31,0	82°	HSS-E 434	323,50 €	
		TiN 4834	374,35 €	
	100°	HSS-E 435	378,95 €	
		TiN 4835	427,50 €	
	120°	HSS-E 433	323,50 €	
		TiN 4833	374,35 €	
6 fraises 6 cutters 6 fresas 6 frese Ø 6,35 ~ 19,05 (1/4" ~ 3/4")	82°	HSS-E 434/5	253,00 €	
		TiN 4834/5	299,25 €	



**Chanfrainage • Lamage / Contersinking • Counterboring**  
*Avelanado • Refrentado / Sbovatura • Svatsatura*